

ENOITALIA

OENOLOGICAL MACHINES

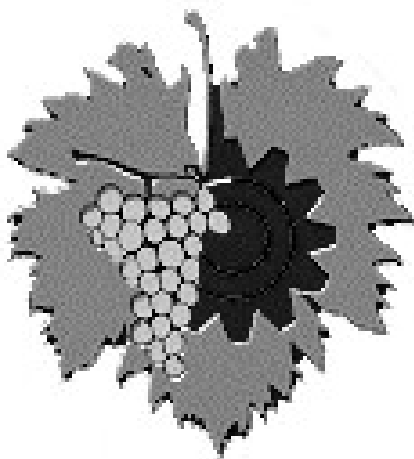

OPERATING INSTRUCTIONS AND TECHNICAL MANUAL

ELLIPTICAL PUMP MODEL GAMMA 180

- *ITALIA*

ENOITALIA s.r.l.
50050 CERRETO GUIDI (FI)
Tel.+39 0571 588031
fax +39 0571/588080
www.enoitalia.net
info@enoitalia.net



IMPORTANT:

This manual must be kept close to the machine in a place known to the staff who will be operating it and carrying out maintenance and repair operations.

INDEX:

- Pag. 3 Legend - Advice
- Pag. 5 Label
- Pag. 5 Limit to the use and safety protection
- Pag. 8 Technical data
- Pag. 8 Transport
- Pag. 9 Manual instruction
- Pag. 10 Installation and first start
- Pag. 11 Adjustment
- Pag. 12 Maintenance
- Pag. 13 Technical drawing and spare part list

LEGEND ADVICE

Inside the manual you can find the following pictogram for:



Read careful

Important information to avoid brake on the machine



Attention: advice to avoid accident to the operator



Prohibition: non allowed action



Maintenance operation that must be made only by specialized operator



Check or change the oil inside the speed reducer



Daily Lubricate with alimentary grease

The label present on the pump are the following



Read carefully the manual (present near the machine)



Attention- avoid touch with hand (present on the unloading area)

Attention – avoid touch with hand because there is a rotating screw
(present on the hopper)



Daily oil (present on the pump body)

Check or change the oil (present on the speed reducer)



Daily Lubricate (present on the pump body)

LABEL

There is a label on the lateral body of the pump as the following:



LIMIT TO THE USE AND SAFETY PROTECTION

The pump Gamma 180 is studied to transfer liquid with solid part in suspension with diameter smaller than 70 mm, and with characteristic of fluency that allow the movement inside the pipe as:

- -Destemmer grape-
- -Grape
- -Wet Must
- -fruit



It is forbidden to use different product, without permission of the

producer

It is forbidden any change on the pump

The machine is composed of a pump with hopper and screw, install on a trolley



To use the pump GAMMA 180 it is necessary one operator, that must be expert how to use the machine



To choose the model and the option, it is necessary have present the following:

1. Hourly production
2. Distance and height of the unloading
3. Fluency of the product ued
4. Dimension of the pipe
5. Loading of the product

1) The machine is available in the following option:

GAMMA 180 HP 5,5 production 14-15 ton/h

GAMMA 180 HP 7,5 production 15-16 ton/h

2) In respect of the distance and height of the unloading, it is possible chose between the motor:

- HP 5,5 with a maximum height 5 meter and distance 30 meter
- HP 7,5 with a maximum height 8 meter and distance 40 meter

3) The distance depend on the fluency of the product

4) The pipe could be rigid or flexible

We suggest to use rigid pipe smooth inside, without reduction of the diameter. The eventually curve must be with a 2,5 diameter

Each curve will reduce the performance of the pump

It is suggested to use *flexible pipe* only for small distance (5/6mt), or if it is necessary frequent movement .

When it is used long pipe or when the product is less fluency (i.e. must) a “battering-arm” could happen. This problem could be resolved with:

-injection of air or gas inside the tube

-compression tank

The **compression tank** is a space where the air is compressed during the use of pump; and this air offset the reduction of the pressure, due to the work of the pump

This tank must be installed between the pump and the pipe.

If the user have a **compressor with air or gas** it is possible connect a tube on the exit of the pump: it will make the same and better work of the compression tank

- 5) The loading inside the hopper could be made:
- A. by a wagon with screw incorporated
 - B. by a fermentation tank with manhole higher than 0,4 mt from the ground
 - C. manually with bin
 - D. automatically by a destemmer that not cover all the dimension of the hopper
 - E. Automatically by a destemmer that cover the hopper: it is not necessary a safety protection for the hopper

All these different solution needs a safety protection for the hopper that allow the security of the operator and also a good work



If it will be used a different solution for loading, it is necessary study a different protection



All this safety protection are necessary to avoid the accidental contact of the operator with the rotating part. They don't stop completely the access to the danger part.

All the operator must be informed don't touch the rotating part at all, and to use an appropriate clothes



If it is not possible to use any of the safety protection indicated, the operator must isolate the area around the pump, in order to avoid the access to the pump during the work

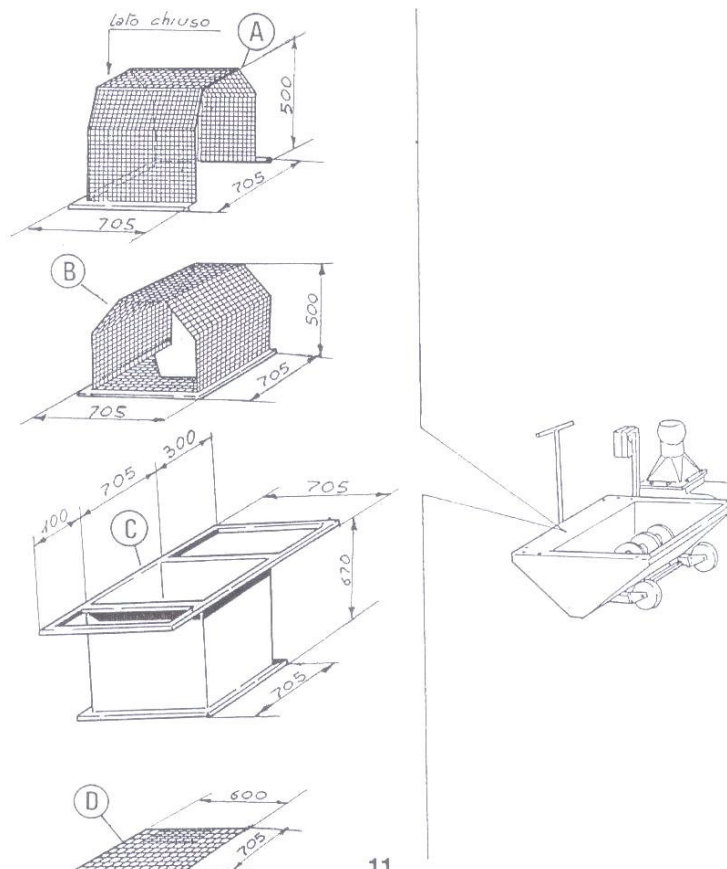

Technical data

Hopper: in stainless steel AISI 304

Screw d.220 mm

Pump: d.300x200mm in stainless steel AISI 304

Engine: 4 kw (5,5 hp)

Voltage: 380V

Inverter : 4kw

Voltage : 220V 60 hz single-phase

LA eq = 75 dB (A)

TRASPORT

For the movement the pump is supplied with a trolley.

THE TROLLEY MUST BE DISASSEMBLED AFTER THE INSTALLATION

For loading , and shipping it is possible use an elevator: insert the fork as in the diagram (one under the pump and one under the hopper)

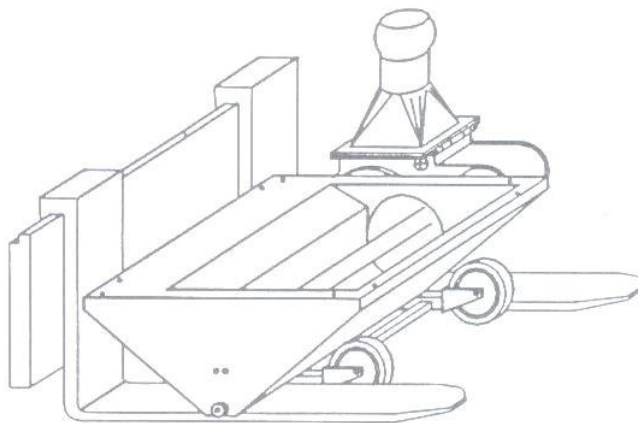

Manual instruction:



The pipe could be rigid or flexible, and smooth inside. Avoid reduction of the diameter.

For high height it is necessary to use compression tank. If is not enough, add liquid or air compressed, till the complete exit of the product. The remaining liquid could be unload by the tap of the hopper, after the operator has raise the valve 66 (it is necessary the special key supplied)



If the pump stop working, disconnect immediately from the electricity and switch off the pump. Call the maintainer of the pump, that must check the reason of the stop:

-The liquid is not fluid, with high viscosity. It is necessary to use the advice above indicated

There is a solid part inside the pump. Open the body of the pump, take off the solid part (it could be under the part 66, between the part 13 and the body of the pump). See if the pump is not damage



The pipe is a protection against the introduction of the hand inside the pump. If it is necessary disassemble the pipe, it is necessary disconnect the pump form the electricity and switch off the panel control

INSTALLATION AND FIRST START



The following operation must be made by the maintainer all the time the pump is move from the installation place:

- Take care the protection of the hopper is assembled to the pump
- Install the pump using the device to stand it on the ground on four vibration-damping feet, and disassemble the trolley
- Check the level of the oil inside the reducer
- Close the stainless steel discharge cone
- Connect the pipe
- Ensure that the circuit tension to which the engines' controls panel is connected is the same as that of the engine cabling
- Check that the engine's voltage corresponds to the voltage of the mains
- To start the machine, proceed with the electrical connection, which must be carried out by a qualified technician. Carefully avoid wetting plug and socket
- The circuit tension must be conformed with the present safety law
- Ensure that there are no part inside the hopper and inside the body of the pump
- Connect the plug to the electricity and press start and immediately the emergency stop. **If the emergency stop dosen't work disconnect immediately the pump from the electricity and contact the reseller or the producer**
- Start again the pump and ensure the rotation is clockwise if you see the motor from the fan side

- The day before the first start, put in operation the automatic lubricator following the manual instruction in attach. Select the position 4 months. Stop at the end of the harvest period

ADJUSTMENT

The inclination of the hopper is adjustable to allow the possibility to reduce the loading height: it is necessary release the connection clamp 10 of the hopper and turn as necessary.

On demand the pump could be supplied with an **inverter speed variator**. The panel control of the inverter could be disassembled during the cleaning of the pump.

The panel control of the inverter is composed of:

- a general red switch;
- a selector for local or remote control;
- a remote control with 15 meter of cord;
- a regulator switch for the speed of the pump;
- a light for alarm of the inverter.

MAINTENANCE



The maintenance must be made by an operator expert and instructed on the safety reglamentation

- lubricate the support and bearing by the greaser n°94. Use alimentary grease
- lubricate the shaft 44 and the support 40 by the greaser with alimentary grease
- these operation must be made daily, and more time per day if the pump is used more than 6/7 hours. These operation must be made while the pump is rotating , the protection are assembled and the cone is closed
- Lubricate the pump before stop for long time



WITH THE PUMP DISCONNECTED FROM THE ELECTRICITY, MAKE THE FOLLOWING OPERATION:

- lubricate the chain with high viscosity oil
- change the oil of the reducer after the first year of work, and each 2 years
- change the seal of the reducer shaft every 2-3 year
- ensure the wear's level of the bronze plate n°67 (for checking move the plate with the supplied key
- clean with hot water and lubricate daily

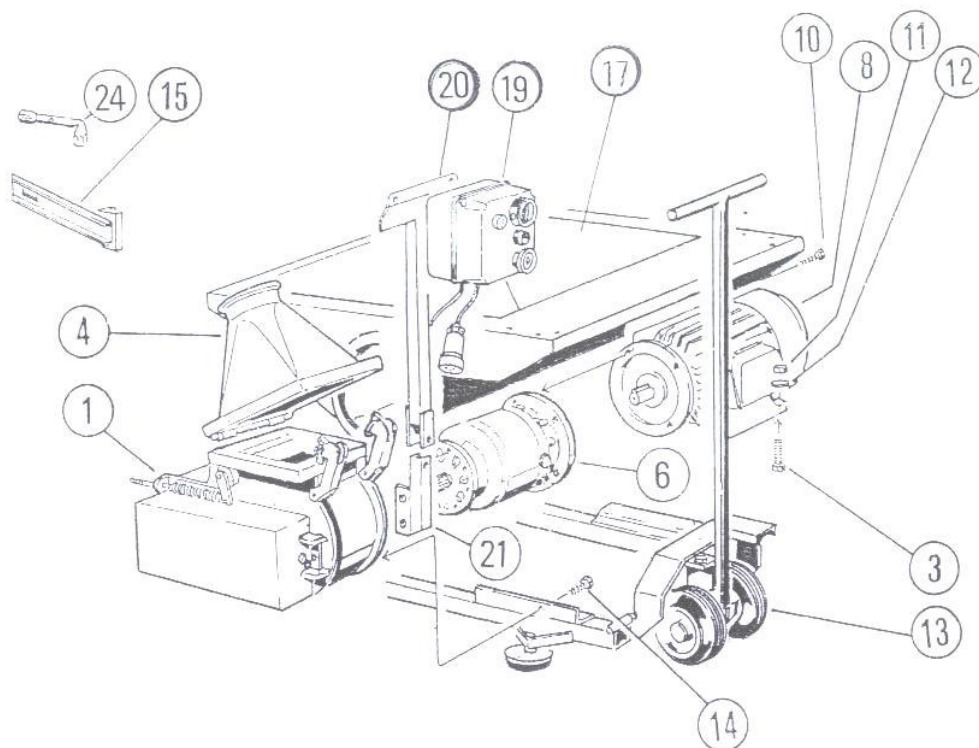

pos.	codice	quant.	descrizione
4	G6.40.000.00	1	Cono ed accessori per lo scarico
6		1	Riduttore
8		1	Motore elettrico
9	VE.10.25B.8Z	8	Vite TE 10x25 8,8 zinc.
10	VE.12.30B.8Z	4	Vite TE 12x30 8,8 zinc.
11	DE.10.GA0.8Z	2	Dado alto Ø 10 8,8 zinc.
12	RN.10.210.0Z	4	Rondella piana 10x21 zinc.
13	VE.10.30B.8Z	2	Vite TE 10x30 8,8 zinc.
14	VE.10.20B.8Z	2	Vite TE 10x20 8,8 zinc.
15	G6.01.G00.00	1	Chiave tappo
16	G6.0A.000.00	1	Pompa G6
17	G6.2A.000.00	1	Tramoggina inox mm. 700x700
19		1	Quadro elettrico
20	G6.6A.A00.00	1	Asta porta interruttore - sezione superiore
21	G6.6A.B00.00	1	Asta porta interruttore - sezione inferiore
22	DA.10.GA0.2X	1	Dado autobloccante Ø 10 inox A2
23	VE.10.55A.2X	1	Vite TE 10x55 Inox A2
24	CH.US.289.19	1	Chiave a pipa Ø 19
25	G6.3B.000.00	1	Carrello inox s/96

TAV.2/2000

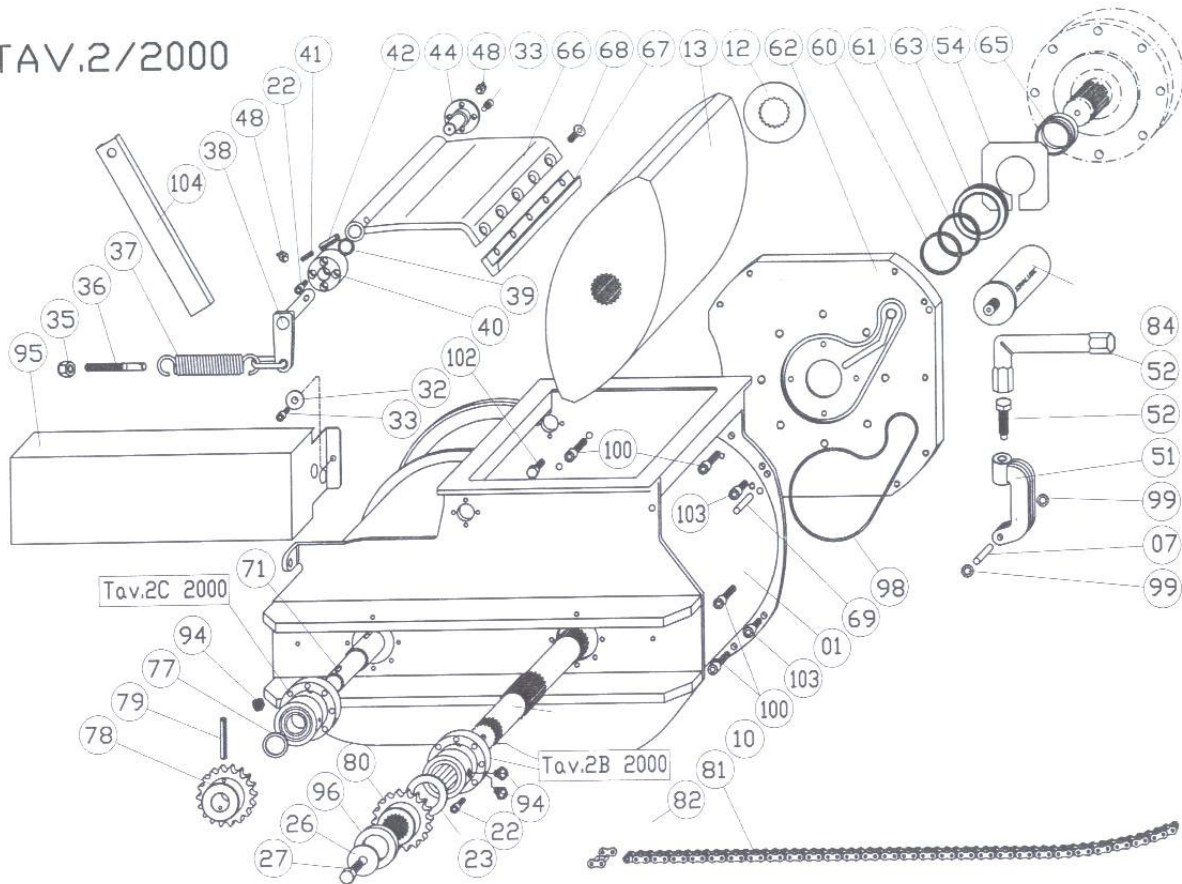

pos.	codice	quant.	descrizione	tav.	pos.	codice	quant.	descrizione	tav.
1	G6.0A.A00.00	1	Corpo pompa s/96	2	66	G6.0A.F02.00	1	Piastra paletta s/96	2
7	G6.01.003.00	2	Rivetto corto	2	67	G6.0A.F03.00	1	Profilo scorrimento in bronzo	2
10	G6.01.005.00	1	Albero oliva inox	2	68	VS.08.16D.2X	5	Vite TSEI 8x16 Inox A2	2
12	G6.01.007.00	1	Rasamento bronzo brocciato	2/A	69	SC.FL.008.24	2	Spina di centratura 8x24	2
13	G6.01.C00.00	1	Oliva	2	70	G6.0E.M00.00	1	Supporto coclea G6/97	2/C
16	VA.06.06F.7Z	1	Grano 6x6 con punta a 90°	2/B	71	G6.0E.015.00	1	Albero coclea G6/97	2/C
17	AG.35.045.04	2	Anello serie G 35x45x4	2/B	72	G6.0E.025.00	1	Schermo supporto coclea s/97	2/C
18	CW.NK.352.00	1	Cuscinetto a rullini NK 35/20	2/B	73	AV.30.047.07	2	Anello di tenuta 30x47x7	2/C
22	VC.06.20C.8Z	20	Vite VTCE 6x20 5931 8,8 zinc.	2	74	G6.0E.026.00	2	Distanziale interno 34x47x2,5	2/C
23	G6.01.012.00	1	Rasamento bronzo 35x54x2	2	75	CV.06.005.2S	2	Cuscinetto 6005 2RS	2/C
26	RN.10.400.0Z	2	Rosetta 10x40 zinc.	2	76	SR.02.047.00	2	Seeger per fori Ø 47	2/C
27	VE.10.20B.8Z	1	Vite TE 10x20 5739 8,8 zinc.	2	77	RN.26.320.0A	1	Rondella alluminio 26x32x1,5	2/C
32	RN.06.140.0X	2	Rosetta 6x14 Inox A2	2	78	G6.0E.023.00	1	Pignone forato 25 H7 - Z 18 - 1/2"	2/C
33	VC.06.10C.2X	6	Vite VTCE 6x10 5931 Inox A2	2	79	SE.ZL.080.25	1	Spina elastica 8x50	2/C
35	DA.10.GA0.8Z	1	Dado autoblocc. Ø 10 8,8 zinc.	2	80	G6.0E.024.00	1	Pignone brocciato 35x31 - Z 18 - 1/2	2
36	G6.01.016.00	1	Registro filettato	2	81	CE.HS.059.01	1	Catena 1/2" - 59 rulli	2
37	G6.01.017.00	1	Molla con occhielli zincata	2	82	CE.HM.000.00	1	Maglia di giunzione 1/2"	2
38	G6.01.E00.00	1	Leva molla	2	84	OT.IN.GR0.01	1	Ingrassatore automatico	2
39	OR.00.121.16	1	OR 121 Ø 16	2	90	G6.0M.L01.00	1	Portaboccole s/2000	2/B
40	G6.01.018.00	1	Boccola paletta	2	91	G6.0M.L02.00	1	Rasamento bronzo con sede OR	2/B
41	SE.ZL.050.25	1	Spina elastica 5x25 zinc.	2	92	AV.35.047.07	2	Anello di tenuta 35-47-7	2/B
42	SE.ZL.080.25	1	Spina elastica 8x25 zinc.	2	93	G6.0M.L03.00	1	Terminali valvola RVD408 8x1	2/B
44	G6.01.019.00	1	Perno paletta	2	94	IN.A1.A00.08	3	Ingrassatore dritto 8xD	2
47	OR.03.137.35	1	OR 3137 Ø 35	2	95	G6.1B.000.00	1	Carter inox s/2000	2
48	IN.A2.G00.06	2	Ingrassatore 6x45°	2	96	G6.0E.027.00	1	Spessore pignone 1/2" Z18	2
51	G6.0A.B00.00	2	Chiusura per cono s/95	2/B	97	VC.06.12C.2X	4	Vite VTCE 6x12 5931 Inox A2	2
52	G6.0E.029.00	2	Vite TE 12x55 Inox A2 tornita	2	98	OR.04.625.A7	1	Guarnizione OR 4625	2
54	G6.01.020.00	1	Disco appoggio anello di tenuta	2/A	99	VF.08.L00.00	4	Fissatori elastici Ø 8	2
60	G6.0A.021.00	1	Distanziale nylon 49x54x2	2/A	100	VC.08.20C.2X	3	Vite VTCE 8x20 5931 Inox A2	2
61	QR.04.226.v0	1	Guarnizione quad-ring 4226 Viton	2/A	101	VC.08.14C.2X	2	Vite VTCE 8x14 5931 Inox A2	2
62	G6.0A.A14.00	1	Piastra attacco riduttore s/96	2/A	102	VE.08.16B.2X	2	Vite TE 8x16 5739 Inox A2	2
63	AV.50.068.08	1	Anello di tenuta 50x68x8	2/A	103	VC.08.16C.2X	1	Vite VTCE 8x16 5931 Inox A2	2
65	G6.0A.004.00	1	Distanziale s/96	2/A					

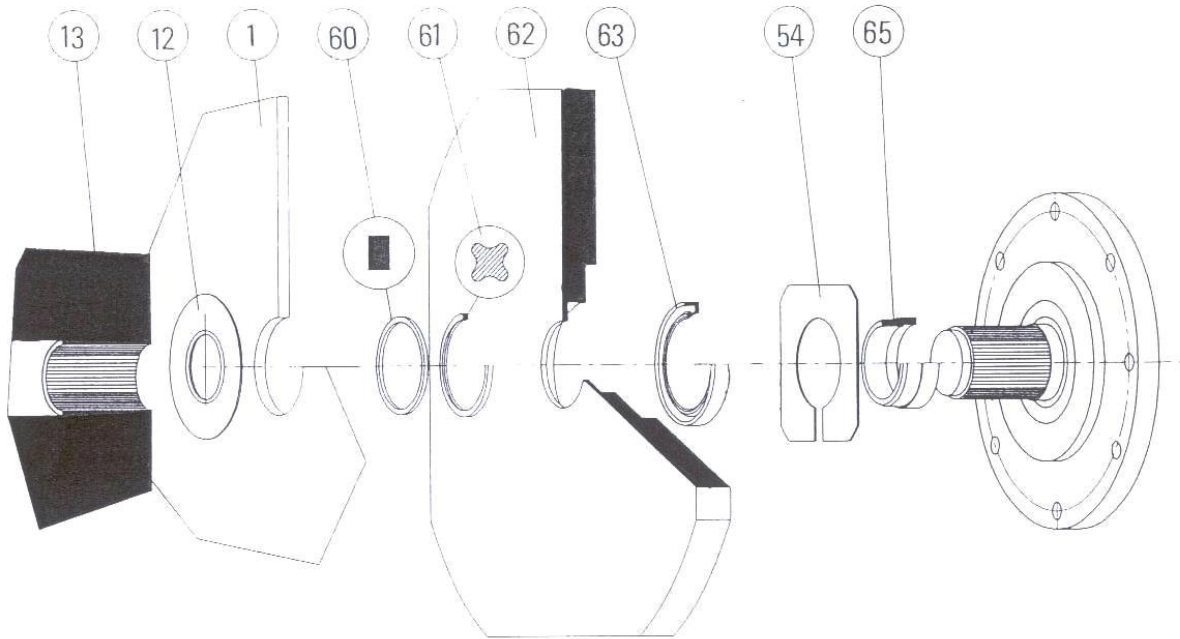

Tav. 2B/2000

SUPPORTO OLIVA

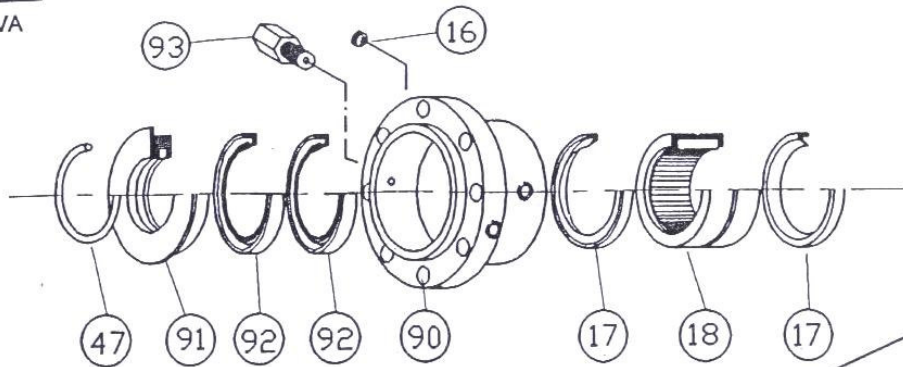

Tav. 2C/2000

SUPPORTO COCLEA

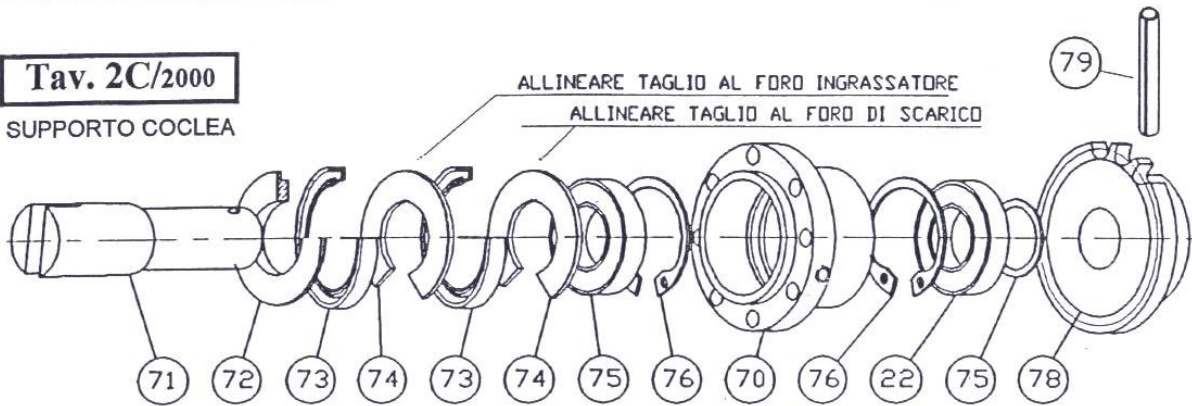

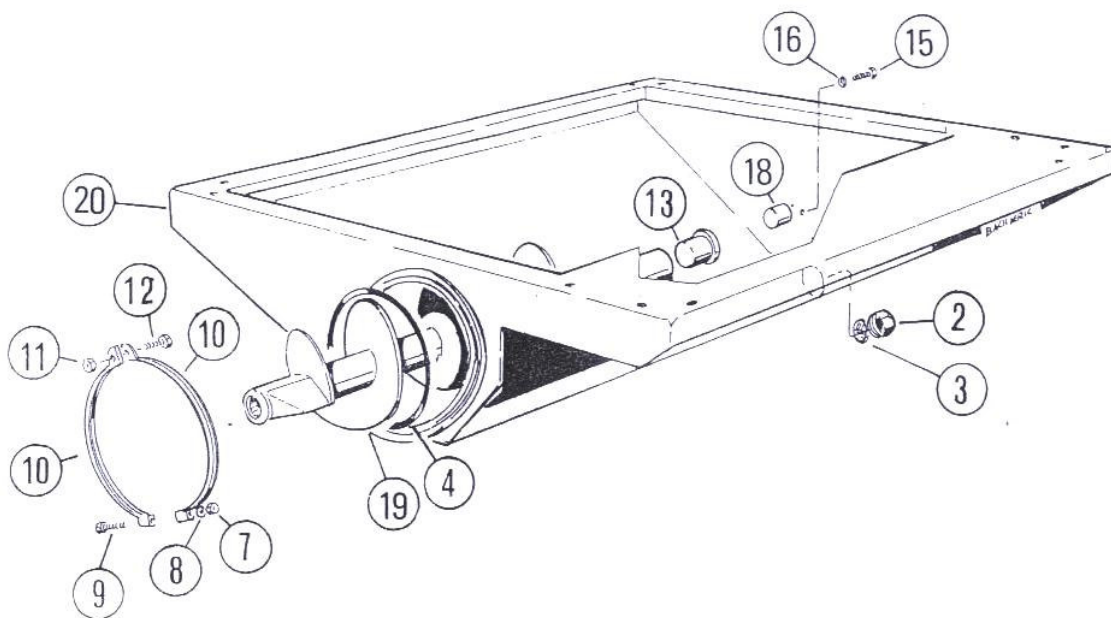

pos.	codice	quant.	descrizione
2	G6.20.003.00	1	Tappo DN 40 Macon in moplen
3		1	Guarnizione tappo
4	CR.GA.006.00	1	Corda OR Ø 6
7	DE.10.GA0.2X	1	Dado alto Ø 10 PG 5587 Inox A2
8	RN.10.212.2X	2	Rosetta Ø 10 6592 Inox A2
9	VE.10.65A.2X	1	Vite TE 10x65 5739 Inox A2
10	G6.20.C00.00	2	Mezza fascetta
11	DE.08.GA0.2X	1	Dado alto Ø 8 PG 5587 Inox A2
12	VE.08.16B.2X	1	Vite TE 8x16 5739 Inox A2
13	G6.20.002.00	1	Boccola nylon per coclea
14	DE.06.GA0.2X	4	Dado alto Ø 6 PG 5587 Inox A2
15	VE.06.15B.2X	4	Vite TE 6x15 3739 Inox A2
	RN.06.140.0X	2	Rondella 6x14 Inox A2
18	G6.2A.001.00	1	Perno coclea s/95
19	G6.8A.000.00	1	Coclea G6 - Ø 220
20	G6.2C.000.00	1	Tramoggina inox mm.700x700